

Mission Success
Ensign-Bickford Aerospace & Defense Company (EBAD) is dedicated to supporting our customers in the aerospace and defense industry through on-time delivery of innovative products that exceed expectations and assure mission success.

Model NPV9000 Product Data Sheet

EBAD's highly reliable Hold Down & Release Mechanisms technology has been adapted for use in Non-Pyrotechnic Valves. The electrically redundant valves offer low shock and positive isolation with both liquid and gas lines. They are available in both normally closed and normally open configurations.

Applications

The Non-Pyrotechnic Valves are most suited to one shot applications that are inaccessible and require maximum reliability such as:

- Spacecraft fuel lines
- Nuclear coolant valves
- Tamper proof hydraulic valves for security applications

Principle of Operation

The NEA® Non-Pyrotechnic Valves consist of a spring-loaded plunger that is restrained using the same patented split-spool and bridge wire technology used in our Hold Down & Release Mechanisms. The spool subassembly includes two spool halves which are held together by a tight winding of a restraining wire that terminates in a bridge wire connecting two electrical terminals at the electrical interface to the device. The spool assembly, by virtue of the restraining wire winding, can prevent axial motion of the plunger. When sufficient electrical current is passed through the terminals and the bridge wire, the bridge wire heats up and breaks under the applied tension load. This allows the restraining wire to unwind, separating the spool halves and releasing the spring-preloaded plunger, which is directly connected to a ball and cone valve mechanism. Actuation can either separate the ball from the cone or engage the ball in the cone depending on the configuration selected.

The actuation method is simple and reliable and forms the basis of actuation for many of EBAD's other products including; Battery Cell Bypass Switches and Pin Pullers.

Key Features

- Electrically Redundant
- Low Shock
- Positive Isolation
- Available in normally closed or open configurations
- Hermetically-sealed designs are available
- Post actuation contamination: <15 items and <25 microns
- Predictable Actuation Times
- Material selections compatible with gas and liquid mediums

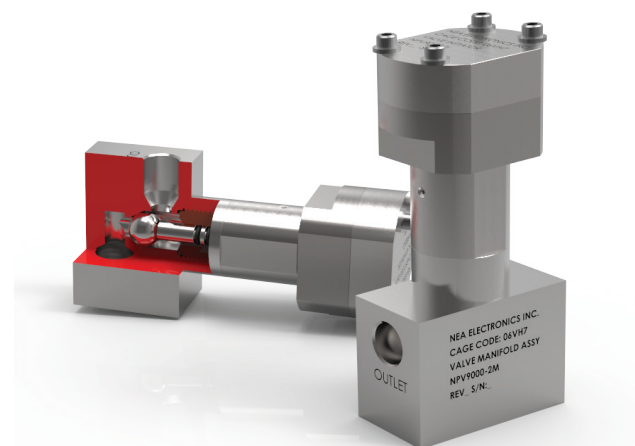

Model NPV9000 Technical Specifications

Parameter	Capability
Burst Pressure (5 minutes)	63.4 MPa (9,200 psi)
Maximum Operational Pressure	31 MPa (4,500 psi)
Minimum Operational Pressure	0 MPa (0 psi)
Minimum Actuation Current ¹	2 A
Actuation Time ²	30 ms
Cold Temperature Limit	-257°C (16 K)
Hot Temperature Limit	+160°C
Mass ³	496.5 g

Notes:

¹Actuation can be achieved using a range of current, the value in the table is the value used for qualifying this device.

²Actuation time is dependent on actuation current, contact applications engineering for more specific information on actuation time as a function of current.

³Mass does not include harnessing and lead wires.

Model NPV9000 Mechanical Interface Drawing

