

Mission Success

Ensign-Bickford Aerospace & Defense Company (EBAD) is dedicated to supporting our customers in the aerospace and defense industry through on-time delivery of innovative products that exceed expectations and assure mission success.

Model 9102G Hold Down & Release Mechanism

EBAD is the global leader in non-pyrotechnic Hold Down & Release Mechanisms (HDRM). Hold Down & Release Mechanisms, also sometimes referred to as Separation Nut Release Mechanisms, are offered in a range of sizes. The Model 9102G supports restrained preloads as high as 17.8 kN (4,000 lbf).

Principle of Operation

The NEA® HDRM is an electrically initiated, one-shot release mechanism that has the ability to carry a very high tensile preload until commanded to release. The preload is applied through a release rod held in place by two separable spool halves which are in turn held together by tight winding of restraining wire. The restraint wire is held in place by redundant electrical fuse wires; actuation of either circuit allows release, assuring maximum reliability. When sufficient electrical current is applied, the restraint wire unwinds allowing the spool halves to separate releasing the release rod and the associated preload.

The actuation is simple and reliable and forms the basis of actuation for many of EBAD's other products including Pin Pullers, Battery Cell Bypass Switches, and Non-Pyrotechnic Valves.

EBAD has the capability to pair our HDRMs with other hardware such as custom release rods, preload nuts, extractors, bolt catchers, mounting brackets, springs, connectors and electrical harnessing to provide low-shock, high reliability release assemblies.

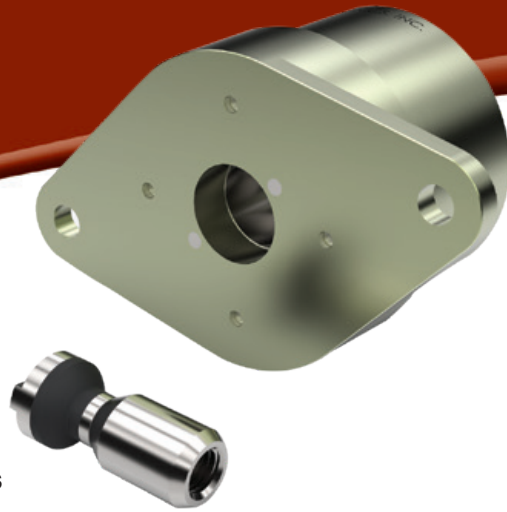

Applications

Typical applications include:

- Antennas
- Scientific instruments
- Solar arrays
- Reflectors
- Satellite, spacecraft and payloads
- Booms and masts
- Launch locks for gimbals, thrusters
- Stage separation
- Caging mechanisms

Key Features

- Extremely low release shock
- Redundant or non-redundant circuit
- Near simultaneous (<10 ms) release of multiple hold-down points
- Extended operating temperature range
- Can be operated with pyrotechnic initiation circuitry
- Range safety friendly
- Space-rated materials
- Factory refurbishment

Model 9102G Technical Specifications

Parameter	Capability
Proof Load Rating	22.2 kN (5,000 lbf)
Release Load Rating	17.8 kN (4,000 lbf)
Shock @ Preload¹	<500 g's @ 17.8kN (4,000lbf)
Fuse Wire Resistance	1.2 to 2.0 Ω @ 25°C
Actuation Current²	4 Amps for 25 ms
No-Fire Current³ (continuity)	250 mA max
Release Time⁴	<50 ms
Temperature Range⁵	-240°C to +135°C
Maximum Angular Misalignment	6° Cone
Mass⁶	130 g (0.29 lb)

Notes:

- ¹ Shock is preload and setup dependent, contact applications engineering for shock at other preloads.
- ² Actuation can be achieved using a range of current, the value in the table is the value used for qualifying this device.
- ³ No-fire current for 5 minutes or less as ambient temperature, consult EBAD applications engineers for other no-fire current requirements.
- ⁴ Release time is dependent on actuation current, preload, and temperature. Contact applications engineering for more specific information on actuation time as a function of current.
- ⁵ The values presented for qualification temperature range are not a measure of the limits of the device.
- ⁶ Mass does not include harnessing and lead wires.

Model 9102G Hold Down & Release Mechanism (HDRM) Mechanical Interface Drawing

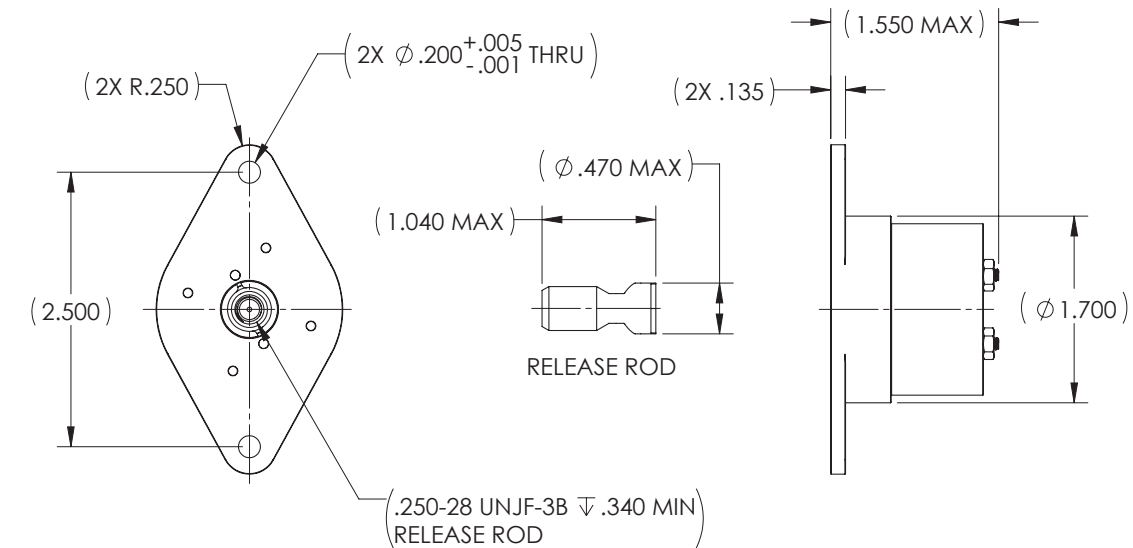

Note: Model 9102G Release Mechanism shown. Different configurations available with alternate release rods, mounting features, and connectors. Metric configurations are also available.