

Mission Success

Ensign-Bickford Aerospace & Defense Company (EBAD) is dedicated to supporting our customers in the aerospace and defense industry through on-time delivery of innovative products that exceed expectations and assure mission success.

Model 9107 Hold Down & Release Mechanism

EBAD is the global leader in non-pyrotechnic Hold Down & Release Mechanisms (HDRM). Hold Down & Release Mechanisms, also sometimes referred to as Separation Nut Release Mechanisms, are offered in a range of sizes. The NEA® Model 9107 supports restrained preloads as high as 195 kN (46,000 lbf).

Principle of Operation

The NEA® HDRM is an electrically initiated, one-shot release mechanism that has the ability to carry a very high tensile preload until commanded to release. The preload is applied through a release rod held in place by two separable spool halves which are in turn held together by tight winding of restraining wire. The restraint wire is held in place by redundant electrical fuse wires; actuation of either circuit allows release, assuring maximum reliability. When sufficient electrical current is applied, the restraint wire unwinds allowing the spool halves to separate releasing the release rod and the associated preload.

The actuation is simple and reliable and forms the basis of actuation for many of EBAD's other products including Pin Pullers, Battery Cell Bypass Switches, and Non-Pyrotechnic Valves.

EBAD has developed a companion HDRM Firing Unit (HFU) that multiplexes a single Launch Vehicle firing order to fire (4) Model 9107's in diagonal pairs or simultaneously. The HFU assures proper current application to the HDRM to assure tight actuation simultaneity between the HDRMs. The HFU provides safety interlocks for Arming and Firing and provides status of HFU and HDRM for integration operations and launch readiness assurance.

NEA® Model 9107
Hold Down & Release Mechanism (HDRM)



Applications

Typical applications include:

- Antennas, reflectors, solar arrays, and deployable radiators
- Booms, masts, and scientific instruments
- Satellite and spacecraft deployment
- Launch vehicle and missile stage and fairing separation
- Missile payload separation

Key Features

- Non-explosive hold down & release function
- High restrained preload
- Extremely low release shock
- High simultaneity of multiple hold-down points
- Wide operating temperature range
- Can be operated with pyrotechnic initiation circuitry
- Space-rated materials
- Factory refurbishments
- More than 20 years of flight heritage
- Flight pedigree on more than 750 space platforms

NEA® Model 9107
Hold Down & Release Mechanism (HDRM)

Model 9107 Technical Specifications

Parameter	Capability
Proof Load Rating	260 kN (58,500 lbf)
Release Load Rating	195 kN (46,000 lbf)
Shock @ Preload¹	<1100 g's @ 195kN (46,000 lbf)
Fuse Wire Resistance	1.2 to 2.0 Ω @ 25°C
Actuation Current²	4 Amps for 60 ms
No-Fire Current³	250mA at 10-5 Torr @ 110° C
Release Time⁴	<50 ms
Operational Temperature Range⁵	-135°C to +135°C
Maximum Angular Misalignment	6° Cone
Mass⁶	2155 g (4.75 lbm)

Notes:

- ¹ Shock is preload and setup dependent.
- ² Actuation can be achieved using a wide range of current
- ³ No-fire current for 5 minutes
- ⁴ Release time is dependent on actuation current, this assumes 4 A current applied.
- ⁵ The values for operational temperature range are not the limits of the device.
- ⁶ Mass does not include harnessing and lead wires.

Model 9107 Hold Down & Release Mechanism (HDRM) Mechanical Interface Drawing

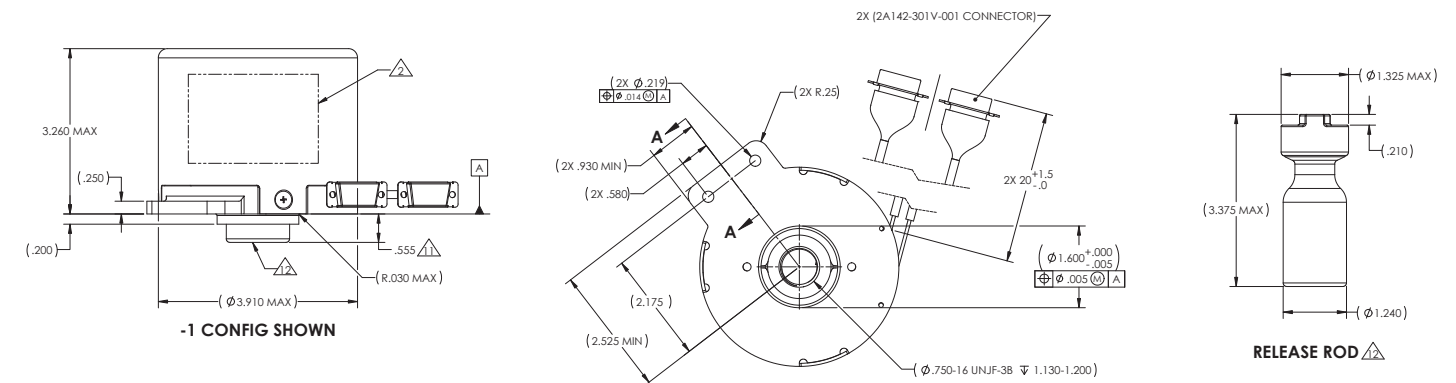

Note: Model 9107 Release Mechanism shown. Different configurations available with alternate release rods, mounting features, and connectors. Metric configurations are also available.