

Mission Success
Ensign-Bickford Aerospace & Defense Company (EBAD) is dedicated to supporting our customers in the aerospace and defense industry through on-time delivery of innovative products that exceed expectations and assure mission success.

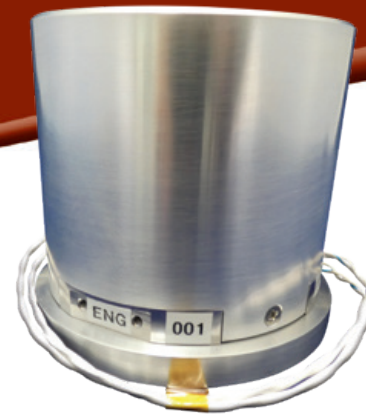

Model 9108 Hold Down & Release Mechanism

EBAD is the global leader in non-pyro Hold Down & Release Mechanisms (HDRM). Hold Down & Release Mechanisms, also sometimes referred to as Separation Nut Release Mechanisms, are offered in a range of sizes. The NEA® Model 9108 supports release loads up to high as 72,000 lbf (320,000 N).

Principle of Operation

The NEA® HDRM is an electrically initiated, one-shot release mechanism that has the ability to carry a very high tensile preload until commanded to release. The preload is applied through a release rod held in place by two separable spool halves which are in turn held together by tight winding of restraining wire. The restraint wire is held in place by redundant electrical fuse wires; actuation of either circuit allows release, assuring maximum reliability. When sufficient electrical current is applied, the restraint wire unwinds allowing the spool halves to separate releasing the release rod and the associated preload.

EBAD has developed a companion HDRM Firing Unit (HFU) that multiplexes a single Launch Vehicle firing order to fire (4) Model 9108's in diagonal pairs or simultaneously. The HFU assures proper current application to the HDRM to assure tight actuation simultaneity between the HDRMs. The HFU provides safety interlocks for Arming and Firing and provides status of HFU and HDRM for integration operations and launch readiness assurance.

EBAD has the capability to pair our HDRMs with other hardware such as custom release rods, preload nuts, extractors, bolt catchers, mounting brackets, springs, connectors and electrical harnessing to provide low-shock, high reliability release assemblies.

Applications

Typical applications include:

- Antennas, reflectors, solar arrays, and deployable radiators
- Booms, masts, and scientific instruments
- Satellite and spacecraft dispensing
- Launch vehicle and missile stage and fairing separation
- Missile payload separation

Key Features

- Non-explosive hold down & release function
- High restrained preload
- Extremely low release shock
- High simultaneity of multiple hold-down points
- Wide operating temperature range
- Can be operated with pyrotechnic initiation circuitry
- Space-rated materials
- Factory refurbishments
- More than 20 years of flight heritage
- Flight pedigree on more than 750 space platforms

Model 9108 Technical Specifications

Parameter	Capability
Proof Load Rating	86,400 lbf (384,000 N)
Release Load Rating	72,000 lbf (320,000 N)
Shock @ Preload¹	<1500 g peak at 76k lbf preload
Fuse Wire Resistance	0.75Ω to 2.0 Ω @ 25°C
Actuation Current²	4 Amps for 60 ms
No-Fire Current³	250 mAmps at 10-5 Torr @ 110°C
Release Time⁴	< 200 ms
Operational Temperature Range⁵	-135°C to +135°C
Maximum Angular Misalignment	3° Cone
Mass⁶	3,855 g (8.5 lbfm)

Notes:

¹ Shock is preload and setup dependent.

² Actuation can be achieved using a wide range of current.

³ No-fire current for 5 minutes.

⁴ Release time is dependent on actuation current, this assumes 4 A current applied.

⁵ The values for operational temperature range are not the limits of the device.

⁶ Mass does not include harnessing and lead wires.

Model 9108 Hold Down & Release Mechanism (HDRM) Mechanical Interface Drawing (for reference)

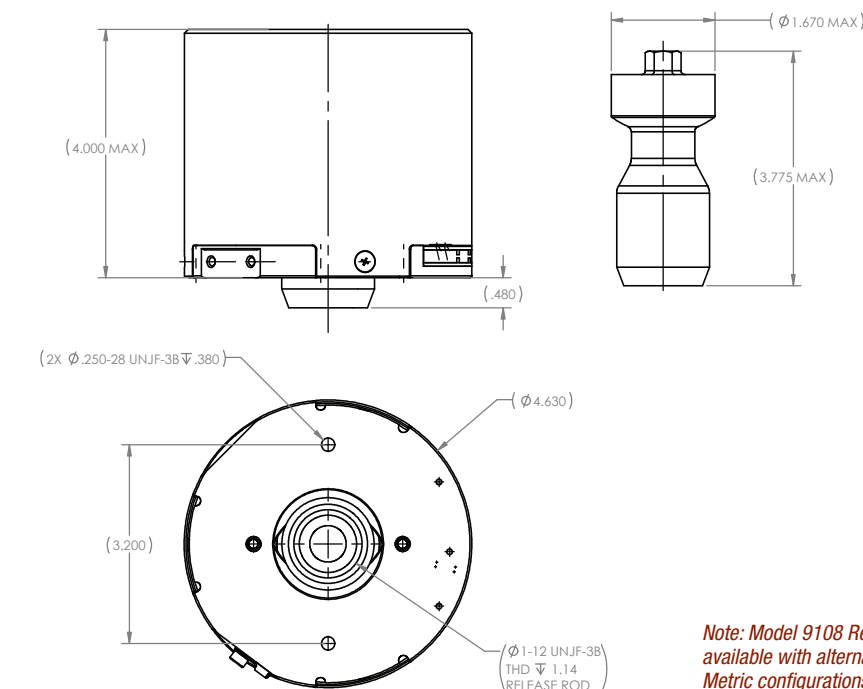

Note: Model 9108 Release Mechanism shown. Different configurations available with alternate release rods, mounting features, and connectors. Metric configurations are also available.

ENSIGN-BICKFORD AEROSPACE & DEFENSE COMPANY
640 HOPMEADOW STREET, P.O. BOX 429, SIMSBURY, CT 06070, USA www.EBAD.com

NEA® is a registered trademark of NEA Electronics, Inc. This product and its components are protected under U.S. Patent Numbers 6,433,990 / 6,249,063 as well as France Patent Numbers 125567 / 9903335, U.K. Patent Number 1255675 and Germany Patent Number 60111923.1.

Attention: The information and recommendations described in this brochure cannot possibly cover every application of the products or variation of conditions under which the products are used. The recommendations here in are based on the manufacturer's experience, research and testing. They are believed to be accurate, but no warranties are made, express or implied. In addition, the specifications contained herein are all nominal which represent our current production. The products described may be subject to change. Please feel free to contact Ensign-Bickford Aerospace & Defense Company for verification. No Warranties or Liabilities: THE PRODUCTS DESCRIBED HEREIN are sold "AS IS" and without any warranty or guaranty, express, or implied, arising by law or otherwise including without limitation any warranty of merchantability or fitness for a particular purpose. Buyer and user agree further to release and discharge seller from any and all liabilities whatsoever arising out of the purchase or use of any product described herein whether or not such liability is occasioned by seller's negligence or based upon strict products liability or upon principles of indemnity or contribution. Content©2022 Ensign-Bickford Aerospace & Defense Company, Simsbury, CT 06070, U.S.A.