

Mission Success

Ensign-Bickford Aerospace & Defense Company (EBAD) is dedicated to supporting our customers in the aerospace and defense industry through on-time delivery of innovative products that exceed expectations and assure mission success.

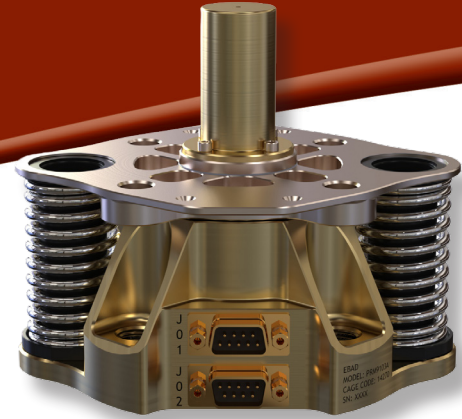

9103A Preloaded

NEA[®] Payload Release Module

The NEA[®] Payload Release Module (PRM) is designed to mount, hold, and release a spacecraft from the launch vehicle upper stage, or from another carrying spacecraft (OTV for instance). The PRM is designed to be used in a multi-point release system (i.e. 4 or 6 point) for spacecrafts up to 1,000 kg in mass.

The PRM utilizes the flight proven NEA[®] 9103 or 9104 as the primary release mechanism, integrating a load carrying interface, separation springs, a bolt extractor, and optional separation switch or separation connector to offer a turnkey dispensing mechanism that is ideal for multi-point satellite release. In a 4-point mount configuration, the PRM is designed to dispense payloads separating laterally or axially from a central dispensing structure. The PRM is delivered fully preloaded, and no custom tools nor on-site training are required for assembly, making integration into space platforms simple and efficient.

Principle of Operation

The PRM is an ultra-low shock, electrically initiated, single-shot, and factory refurbishable release mechanism that has the ability to carry a high tensile preload until commanded to release. The preload is applied through a release rod held in place by two separable spool halves which are in turn held together by tight winding of restraining wire. The restraint wire is held in place by redundant electrical fuse wires; actuation of either circuit allows release, assuring maximum reliability. When sufficient electrical current is applied, the restraint wire unwinds allowing the spool halves to separate releasing the release rod and the associated preload. The tunable separation springs provide the push off force to achieve the required separation velocity.

The PRM has a location to hold either a telemetry separation switch or 37 pin separation connector. The telemetry switch is commonly used to verify spacecraft separation from the launch vehicle, and the separation connector can be used for separation detection, ground power delivery or communications from the launch vehicle to the spacecraft.

Applications

Typical applications include:

- Satellite and spacecraft dispensing
- Launch vehicle and missile stage fairing separation
- Missile payload separation

Key Features

- Ultra-low release shock
- Redundant actuation circuit
- Can be operated with standard launch vehicle firing circuitry
- Launch vehicle to payload connector interface
- Non-explosive hold down & release function
- No debris generation
- High simultaneity of multiple hold-down points
- Customizable separation velocity
- Wide operating temperature range
- Qualified to standard launch environments
- Factory refurbishment available
- NEA[®] HDRM with more than 25 years of flight heritage

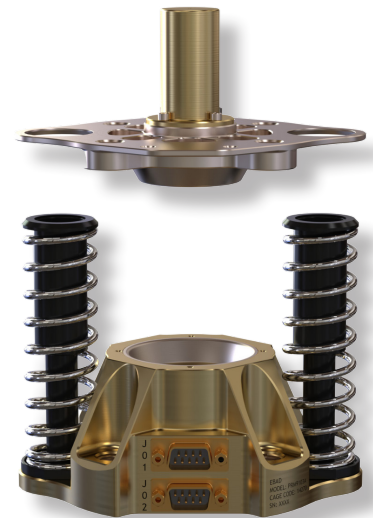

9103A Released



Scan to view the PRM 9103A animation.

NEA® Payload Release Module – Technical Specifications

| Parameter | PRM 9103A | PRM 9104A |
|--|---------------------|---------------------|
| Axial Preload | Up to 8,500 lbf | Up to 15,000 lbf |
| Axial Stiffness | 2.02 E+6 lbf/in | 9.28 E+5 lbf/in |
| Shear Stiffness | 9.0 E+5 lbf/in | 5.98 E+6 lbf/in |
| Bending Stiffness | 7.5 E+5 in-lbf/rad | 2.38 E+6 in-lbf/rad |
| Shock Output | <300 g's | <500 g's |
| Actuation Current | 6 Amps for 15 ms | 6 Amps for 15 ms |
| Release Time | <40 ms | <50 ms |
| Total Mass | 3.6 lbm | 6.5 lbm |
| Flyaway Mass | 1.4 lbm | 1.8 lbm |
| Temperature Range | -90°C to +135°C | -90°C to +135°C |
| Total Spring Energy per PRM (configurable) | 2.82 to 16.2 Joules | 2.82 to 20.6 Joules |

NEA® Payload Release Module – Mechanical Interface Drawing

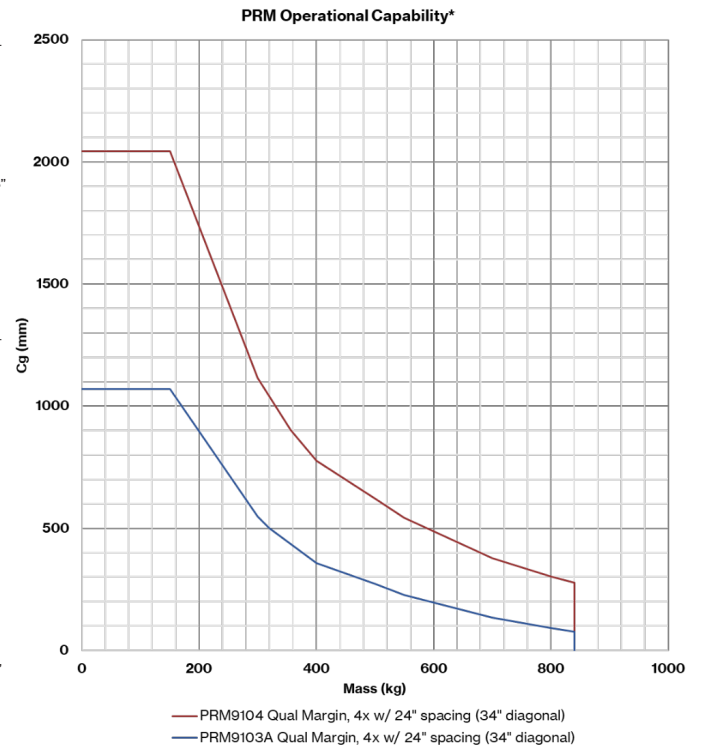
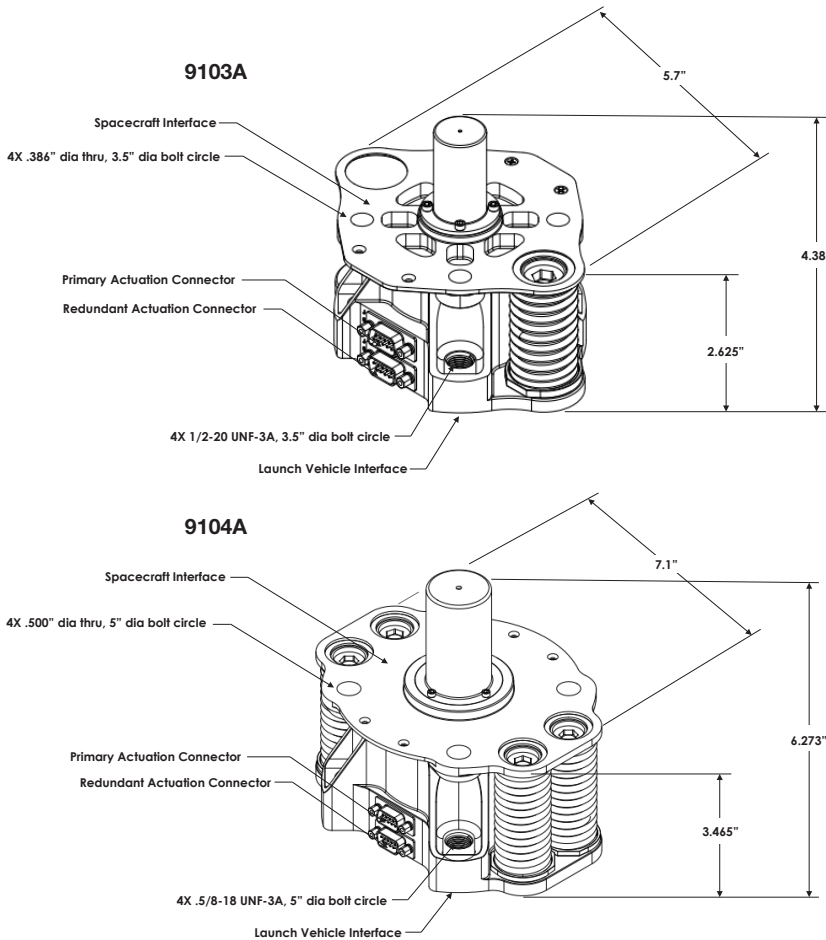

*Includes 1.25x qual margin to F9 RPUG environments

ENSIGN-BICKFORD AEROSPACE & DEFENSE COMPANY
 640 HOPMEADOW STREET, P.O. BOX 429, SIMSBURY, CT 06070, USA www.EBAD.com

Attention: The information and recommendations described in this brochure cannot possibly cover every application of the products or variation of conditions under which the products are used. The recommendations here in are based on the manufacturer's experience, research and testing. They are believed to be accurate, but no warranties are made, express or implied. In addition, the specifications contained herein are all nominal which represent our current production. The products described may be subject to change. Please feel free to contact Ensign-Bickford Aerospace & Defense Company for verification. No Warranties or Liabilities: THE PRODUCTS DESCRIBED HEREIN are sold "AS IS" and without any warranty or guaranty, express, or implied, arising by law or otherwise including without limitation any warranty of merchantability or fitness for a particular purpose. Buyer and user agree further to release and discharge seller from any and all liabilities whatsoever arising out of the purchase or use of any product described herein whether or not such liability is occasioned by seller's negligence or based upon strict products liability or upon principles of indemnity or contribution.

Content ©2021 Ensign-Bickford Aerospace & Defense Company, Simsbury, CT 06070, U.S.A.